

BUNGALOW MAINTENANCE

101

How to Care for Your Vintage Home



CHICAGO BUNGALOW ASSOCIATION

Why Maintain Your Chicago Bungalow?

A HEALTHY HOME MEANS HEALTHY INHABITANTS

To have a healthy home, keep it dry, clean, well-ventilated, free from contaminants, pest-free, safe, and well-maintained. Regular maintenance can reduce allergens, prevent illness, and reduce injury from accidents.

OWNING A HOME IS THE SINGLE LARGEST INVESTMENT YOU'LL EVER MAKE

By maintaining your home, you're helping to ensure not only a safe and healthy home, but strong curb appeal and a good resale value. Older homes like Chicago bungalows tend to maintain their resale value more than newer construction, so take care of that vintage beauty and she'll take care of you.

REGULAR MAINTENANCE EXTENDS THE LIFE OF YOUR MECHANICAL SYSTEMS

Seasonal changes put extra stress on your heating and cooling systems, especially in Chicago! There are many components to these systems, and without proper maintenance, one or more of these pieces may fail when you need them most. A properly maintained system not only ensures a comfortable February, it will lower your utility usage and operating costs by running more efficiently, and ensure that the most expensive appliance in your home doesn't need to be replaced.

...and because you should be comfortable and happy in your home!

TABLE OF CONTENTS

HEALTH & SAFETY

Detecting the Invisible	3
A Safe Electrical System	4
Mold Prevention	5
Lead Paint	6
The Air We Breathe	7
Green Cleaning	8

START AT THE TOP: MAINTAINING YOUR ROOF

The Shingle Life	15
Gutters	16
Flashing	17
Ice Dams	18

THE WALLS

Masonry	21
Windows	25

2 HEALTHY PIPES! HEATING AND PLUMBING 28

Steam and Hot Water Heat	29
Common Plumbing Issues	30

ENERGY SAVING MEASURES 32

Mechanical Systems	33
Air Sealing and Insulation	34

14 DETERMINING A MAINTENANCE PLAN 38

General Tips	39
Drafting a Plan of Attack	40

GLOSSARY 41

HEALTH & SAFETY

While it's fun to think about rehabbing your kitchen or restoring your crown molding, your top priority should always be health and safety. ***Ensure that your home is safe and healthy before planning cosmetic changes.***

Potential Carbon Monoxide Sources in the Home

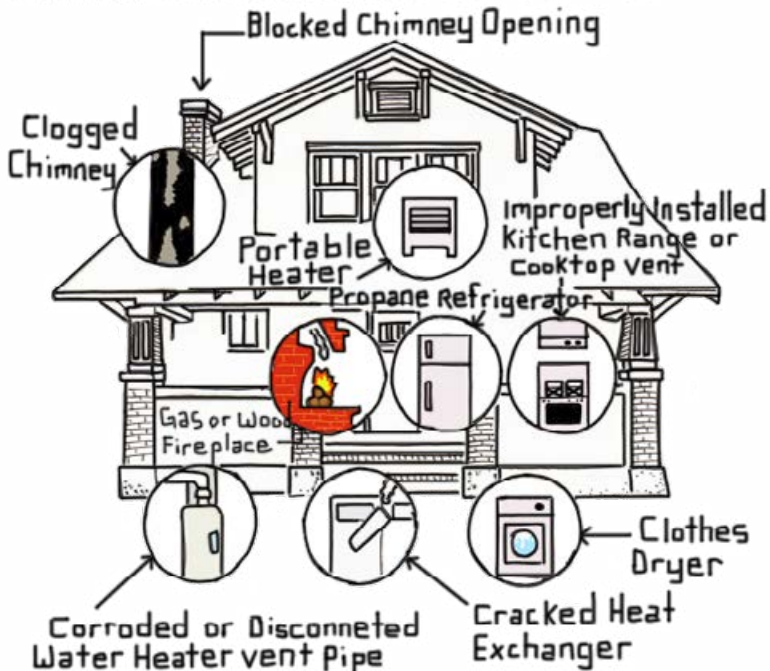

DETECTING THE INVISIBLE

Radon. Studies have revealed that Chicago has high levels of radon in many areas of the city. Radon gas occurs naturally underground and you can easily test its levels by hanging an inexpensive detector in your basement. Because radon is the second leading cause of lung cancer, it's especially important to test your home before air sealing and insulating, or you may create a much more serious air quality problem by trapping harmful gasses inside.



Smoke Detectors. According to the National Fire Protection Association, you should install smoke alarms inside each bedroom, outside each sleeping area and on every level of the home, including the basement. On levels without bedrooms, install alarms in the living room (or den/family room) or near the stairway to the upper level, or in both locations.

Over 41% of homes tested in Illinois have radon amounts above the EPA action level and up to 1,160 people in Illinois develop radon-related lung cancer each year.

- > Always have an escape plan. Escape plans help you get out of your home quickly. In less than 30 seconds a small flame can get out of control and turn into a major fire.
- > Be sure to have a working fire extinguisher in your home...and know how to use it!

Pull
Aim
Squeeze
Sweep

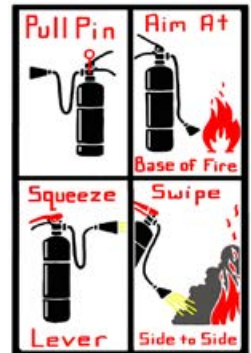

Carbon Monoxide (CO). This poisonous gas is colorless, odorless, and tasteless, so it's incredibly important to have a detector in your home. If you are installing only one CO detector, the Consumer Product Safety Commission recommends it be located near the bedroom, where it can wake you from sleep. Additional detectors on every level and in every bedroom of a home provides extra protection.

On average, 67 Illinoisans die from carbon monoxide exposure each year, which is more than in any other state.

Regular Maintenance for Carbon Monoxide Safety

- > Have fuel burning appliances installed and serviced twice a year by a professional to ensure proper working order.
- > Replace dirty air filters on heating and cooling systems.
- > During winter months, check often to ensure vents, flues, and chimneys are not blocked by snow or ice.
- > Do not use a gas range or oven to heat your home.
- > Never run your car in a closed garage.
- > Never run a generator, power washer or any diesel or gasoline-powered engine inside a basement, garage, enclosed structure, or near open windows.

KNOW THE SIGNS AND SYMPTOMS OF CARBON MONOXIDE POISONING



A SAFE ELECTRICAL SYSTEM

- > U.S. fire departments respond to an estimated annual average of 50,000 reported home structure fires involving electrical failure or malfunction.
- > Most bungalows originally had knob and tube (K&T) wiring. If this hasn't been replaced, you may want to consider rewiring in case the rubberized cloth or ceramic tubes have been compromised, and to reduce the risk of a fire hazard caused by modern appliances. This wiring was installed from the 1890s into the 1930s, but with the expectation of running little more than light bulbs. The presence of this kind of wiring may also affect your ability to insure your home, so it's a good idea to explore that issue before purchasing or selling a home with K&T wiring.
- > Replace or repair damaged or loose electrical cords.
- > Avoid running extension cords across doorways or under carpets.

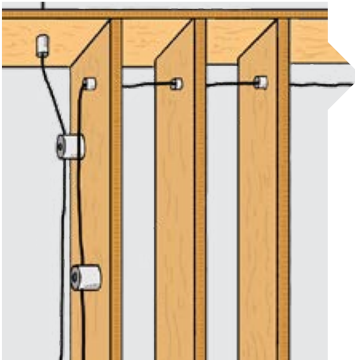

Knob and tube wiring

- > In homes with small children, make sure your home has tamper-resistant (TR) receptacles.
- > Consider eliminating the need for extension cords by having additional circuits or outlets installed by a qualified electrician.
- > Avoid overloading outlets. Plug only one high-wattage appliance into each receptacle outlet at a time.
- > If outlets or switches feel warm, have frequent problems with blowing fuses or tripping circuits, or flickering or dimming lights, call a qualified electrician.
- > Make sure your home has ground fault circuit interrupters (GFCIs) in the kitchen, bathroom(s), laundry, basement, and outdoor areas.
- > Arc-fault circuit interrupters (AFCIs) should be installed in your home to protect electrical outlets.

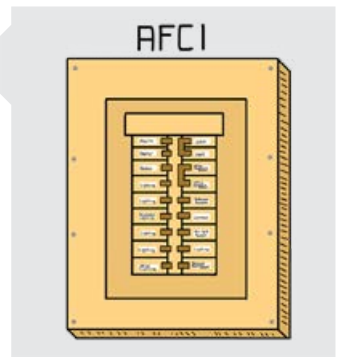
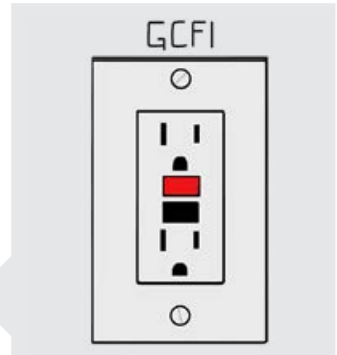

MOLD PREVENTION

- > Keep humidity levels in your home below 50% at all times by using an air conditioner or dehumidifier when necessary.
- > Use exhaust fans in your kitchen and bathrooms.
- > Make sure that all of your exhaust fans and your clothes dryer vent to the outside.
- > Fix any leaks in your roof, walls, and plumbing.
- > Be sure to clean up and dry out your home within 24-48 hours after flooding.
- > Add mold inhibitors to paints before painting.
- > Clean bathrooms with mold-killing products.
- > Remove or replace carpets and upholstery that cannot be dried properly after flooding.
- > Consider removing carpeting in rooms like bathrooms or basements that tend to have a lot of moisture.

Getting Rid of Mold

- Always address the source of the moisture first!
- Use soap and water to scrub mold off of hard surfaces—you do not need to use harsh chemicals, which can contribute to asthma, among other dangers.
- Carpet and furniture may have to be thrown out if they contain mold (never fun, but sometimes necessary).
- Wear protective gear. Once you disturb the mold, spores detach and start floating everywhere. Spores can attach to your clothing and shoes and be spread into other areas of your home, in your eyes, and up your nose and into your upper respiratory system.

At a minimum, wear non-vented goggles, rubber gloves, a partial face paper respirator (EPA recommends an N-95), and old clothing items you can toss when finished cleaning, or wash separately from your normal laundry.

- If the mold covers more than 10 square feet of space, contact a professional mold remediator. Visit our trusted referral page at www.chicagobungalow.org.

LEAD PAINT

Lead paint is present in almost all vintage homes as it was commonly used in homes built before 1978. It is especially dangerous for children to eat or absorb lead through their skin, so here are some precautions all families should take before doing any kind of work that will disturb paint in their homes:

- Choose work methods that create the least amount of dust; lead dust can be breathed in or absorbed through the skin, so wash clothes if they have come in contact with any lead dust.
- Keep children, pregnant women, and non-workers out of the area.
- Cover floors and furniture with plastic.
- Use a vacuum with HEPA filters and wet-clean thoroughly.
- Visit www.epa.gov/lead for important resources.
- Or, hire a certified lead contractor to remove the lead risk.



Worried about Lead Levels in Your Water? Here are a Few Things You Can Do:

Have your water tested. Many public water systems will test drinking water for residents upon request. Chicago residents can call 311 for information. You can also check the State of Illinois' drinking water website for more information at www2.illinois.gov/epa/topics/drinking-water/.

Be aware of any work that could disturb your lead service line, such as water main replacement, lead service line repair or replacement of part of the service line.

Run water before use if it has not been used for several hours.

Use only cold water for drinking, cooking, and preparing baby formula.

Purchase a water filter that is certified to remove lead.

Regularly remove any debris from faucet aerators—particles of lead may become trapped in the aerator.

Purchase lead-free faucets and plumbing components.

THE AIR WE BREATHE

More than 8% of adults and 7% of children have asthma in Illinois. Symptoms can be triggered and made worse with poor indoor air quality due to numerous factors including dust and pet hair. Dusting and mopping are about more than just looking tidy—they can have a major effect on our health!

Tips for keeping your home clean:

Control the source of dust and contaminants in your home.

- Remove shoes, brush and bathe pets, etc.

Reduce clutter.

- Create smooth and cleanable surfaces so you can keep dust under control. When things pile up, it is much harder to clean effectively (and much less fun!).

Don't just move the dust around.

- Use “wet cleaning” to prevent particles from simply moving around and into the air.

GREEN CLEANING

Once you've created easy-to-clean surfaces, make sure you don't clean with products that will give you a headache—literally. Many of the cleaning products available in stores are toxic and can actually make your indoor air quality worse, despite picking up the dust. Poor indoor air quality can lead to chronic respiratory diseases, headaches, dry eyes, nasal congestion, nausea, and fatigue.

In a pinch, you can find safer commercial products like Simple Green and Method brand products in stores. Or, avoid chemicals—and save money—with this comprehensive list of non-toxic cleaning alternatives!

Here's a handy list of healthy, nontoxic alternatives for year-round cleaning:

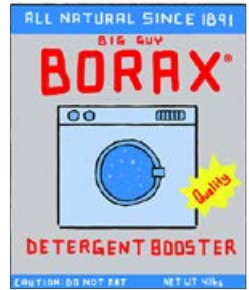

GENERAL CLEANERS

Household Cleaner

Mix together:

1 tsp. liquid soap (castile, peppermint)

1 tsp. borax

Squeeze of lemon

1 qt. warm water

OR

1/4 c. baking soda

1/2 c. borax

1/2 c. vinegar

1 gal. water

For surfaces that need scouring, try moist salt or baking soda and a green scouring pad.

Window Cleaner

Mix together:

2 tsp. vinegar

1 qt. warm water

OR

2 tbsp. borax

3 c. water

Rub dry with newspaper to avoid streaking.

Disinfectant

Mix together:

1/4 c. borax

1/2 gal. hot water

KITCHEN/BATHROOM CLEANERS

Ovens:

Mix together:

1/4 c. baking soda

2 tbsp. salt

Hot water, as needed to make a paste.

Let paste sit for 5 minutes. Keep off wires/heating elements!

OR

2 tbsp. liquid soap (castile, peppermint)

2 tsp. borax

1 qt. warm water

Spray on oven and wait 20 minutes, then clean. For tough stains, scrub with very fine steel wool and baking soda.

Drains:

Pour together:

1/2 c. borax in drain, followed by

2 c. boiling water

OR

1/4 c. baking soda down the drain, followed by

1/2 c. vinegar

Cover drain and let sit for 15 minutes.

Follow with 2 qts. boiling water.

OR

Use a plumber's "snake" and boiling water.

Toilet Bowls:

Pour:

1/4 c. baking soda into bowl and drizzle with vinegar.

Let sit for 1/2 hour. Scrub and flush. Add borax for stains.

Air Fresheners:

Commercial fresheners work by masking smells, coating nasal passages and deadening nerves to diminish sense of smell.

Instead:

Find source of odors and eliminate them.

Keep house and closets clean and well-ventilated.

Grow lots of houseplants!

Simmer:

Cinnamon sticks, orange peel, cloves, and water.

To absorb odors, place 2 to 4 tbsp. baking soda or vinegar in small bowls in refrigerator and around the house and pour 1/2 c. baking soda in the bottom of trash cans.

Ceramic Tiles:

Mix together:

1/4 c. vinegar

1 gal. warm water

Basin, Tub, and Tile:

Mix together:

1/2 c. baking soda

2-3 tbsp. liquid soap (castile, peppermint)

Garbage Disposal Freshener:

Grind ice and lemon or orange juice in the disposal.

Mildew Remover:

Dissolve together:

1/2 c. vinegar

1/2 c. borax in warm water.

Apply with sponge or spray bottle.

RUGS/FLOORS

Rug and Upholstery Cleaner:

Sprinkle cornmeal, baking soda or cornstarch on dry rugs and vacuum. Use club soda or soap-based rug shampoo.

Carpet Cleaning Foam:

Mix together:

1/4 c. vegetable oil-based liquid soap

3 tbsp. (or more) water

Whip ingredients in bowl with egg beater.

Rub foam into problem areas of the rug.

Rinse well with water.

Floors:

Mix together:

1/2 c. white vinegar

1 gal. warm water

Polish with skim milk after floor is dry—this will make the floor glow!

FURNITURE

Furniture Polish (Wood Surfaces):

Rub toothpaste on wood furniture to remove water marks.

Polish wood with 2 tsp. lemon oil and 1 pint mineral oil in a spray bottle. Spray, rub in and wipe clean.

Mix two parts olive oil to one part lemon juice. After rubbing the mixture in, let stand for several hours and then polish with a soft, dry cloth.

Melt 1 tbsp. carnauba wax into two pints mineral oil. Use sparingly and rub hard.

METAL POLISHES/CLEANERS

Silver:

Soak:

1 qt. warm water

1 tsp. baking soda

1 tsp. salt

Small piece of aluminum foil

Copper:

Rub lightly with fine table salt wetted with vinegar and lemon juice.

Chrome:

Rubbing alcohol, or a small amount of ammonia with hot water. Also try white flour in a damp rag.

Brass:

Equal parts salt and flour, with a little vinegar.

PET HEALTH

Feed your pet one tablet (or 1 tbsp.) brewers yeast daily to give their skin a scent that fleas avoid.

Place cedar chips around bedding area.

Comb with a flea comb.

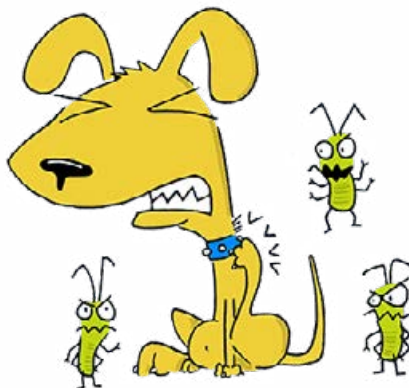

HOBBIES/CRAFTS

Use wheat pastes, glue sticks or double-sided tape instead of petroleum-based glues or spray fixatives.

Use water-based, unscented, non-toxic markers.

Use water-based, non-toxic paints and inks which also reduce the need for solvent cleanup.

LAUNDRY

When making the initial switch from a detergent to a soap laundry cleaner, wash items once with washing soda only. This will eliminate detergent residues that might otherwise react with soap to cause a yellowing of fabrics.

Laundry Soap:

Add 1/3 c. washing soda (sodium carbonate) to water as machine is filling. Add clothes. Add 1 1/2 c. of soap. If the water is hard, add another 1/4 c. soda or 1/4 c. vinegar during the first rinse.

Add 1/3 c. washing soda to water before placing clothes in machine and substitute soap flakes or powder for detergent. Add 1/2 c. borax for additional cleaning power.

Pre-soak:

Soak heavily soiled items in warm water with 1/2 c. washing soda for 30 minutes. Rub soiled areas with liquid soap.

Fabric Softener:

Add 1 c. vinegar or 1/4 c. baking soda during final rinse. To reduce static cling in tumble-dried synthetics, dampen hands when folding or line dry instead.

Spray Starch:

Dissolve 2 tbsp. cornstarch in 1 pint cold water in a spray bottle. Shake before each use. For delicate fabrics, dissolve 1 package unflavored gelatin to 2 c. of hot water. Dip a corner of the fabric into the solution to test; if fabric becomes sticky when dry, add more water.

Dry Cleaning:

Buy items you can wash or clean on your own. Most dry cleaning solvents, such as perchloroethylene are toxic. If you must dry clean, air clothing out thoroughly before bringing indoors. Many garments whose labels specify "dry clean only" can be safely hand-washed using mild soap.

SPOT REMOVERS

Here are alternatives to enzyme pre-soaks and bleach for tough stains. Test each of the following remedies on a corner of your fabric first. Wash after application.

Heavy Soils:

Rub with solution of 2 tbsp. washing soda in 1 c. warm water.

Fruit and Wine:

Immediately pour salt or hot water on the stain and soak in milk before washing.

Ink:

Soak in milk or remove with hydrogen peroxide.

Coffee:

Mix egg yolk with luke-warm water and rub on stain.

Lipstick:

Rub with cold cream or shortening and wash with washing soda.

Mildew:

Pour strong soap and salt on the spots and place in sunlight. Keep the spots moist, and repeat as often as necessary.

Soiled Diapers:

Pre-soak in 3 tbsp. baking soda dissolved in warm water in either a bucket or washing machine.

Grease:

Pour boiling water on stains and follow with dry baking soda. Also try ammonia and water.

Blood:

Soak in cold water or remove with hydrogen peroxide. For a more stubborn stain, mix cornstarch, talcum powder or cornmeal with water and apply to stain. Allow to dry and brush away.

Chewing Gum:

Rub with ice. Gum will flake off.

Rust:

Saturate with sour milk (or lemon juice) and rub with salt. Place in direct sunlight until dry, then wash.

Scorches:

Boil scorched article in 1 c. soap and 2 qts. milk.

VOLATILE ORGANIC COMPOUNDS (VOCs)

VOCs are found in thousands of household products, so while it may be difficult to avoid them all, you can still minimize exposure. VOCs include a variety of chemicals, some of which may have short- and long-term adverse health effects.

Tips to Reduce Exposure to VOCs

- > Increase ventilation when using products that emit VOCs via vents and fresh air.
- > Pay attention to precautions listed on the labels of products and meet or exceed their recommendations.
- > Do not store opened containers of unused paints and similar materials inside your home.
- > Use household products according to manufacturer's directions.
- > Throw away unused or little-used containers safely; buy in quantities that you will use up quickly.
- > Keep containers out of reach of children and pets.
- > Never mix household products unless directed to do so on the label.

PESTS!

No, we don't mean that nosy neighbor, though we recommend a peep hole, a fake moustache, and tall fences in such instances. Bugs and vermin are not only unwanted roommates, they can also create real health hazards. Mice and cockroaches can actually enhance asthma episodes in children, and pesticide residues in homes pose risks for neurological damage and even cancer if not administered properly.



What to do?

- > Consider Integrated Pest Management (IPM) strategies!
- > If needed, use sticky-traps and baits in closed containers.
- > Seal cracks and openings throughout the home so pests can't get in.
- > Store food in pest-resistant containers.

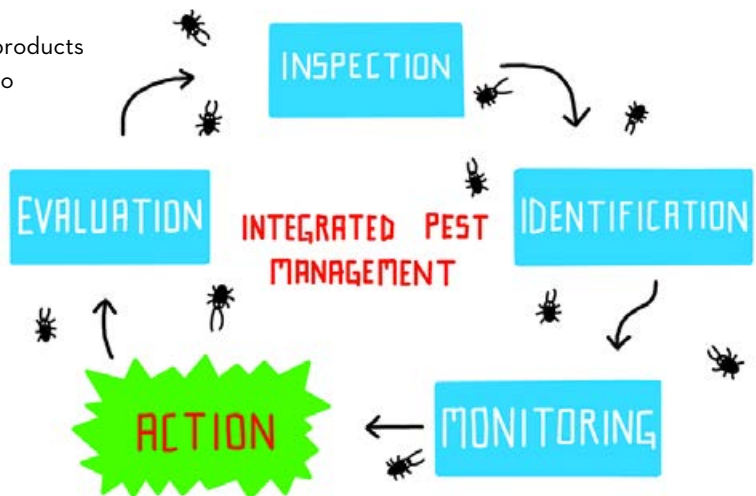

START AT THE TOP: MAINTAINING YOUR ROOF

Once you've ensured that your home is safe to inhabit, it's time to tackle issues that affect the physical integrity of your largest investment.

As a rule, always start at the top, because having a well-sealed roof is a must.



THE SHINGLE LIFE

How to Determine if Shingles Need Replacing

Curling edges. This is a common problem that compromises the ability of your shingles to keep water out. It is generally caused by a heat buildup in your attic, so make sure your attic is properly vented with soffits and a ridge vent (or other roof vent).

Cracks in your shingles. Cracks naturally occur over time as shingles become rigid and no longer pliable due to damage caused by ultraviolet rays from the sun.

Balding. If you notice granules in your gutters, they are likely coming from your shingles. This is a sign that they are balding due to wear and tear and likely nearing the end of their life.

NOTE: *While shingles claim to last 20, 25, or 30 years, these numbers are determined in laboratories where weather doesn't exist. Roof pitch, sunlight, heat, cold, and prevailing winds will knock about 5 years off the listed life of your shingles.*

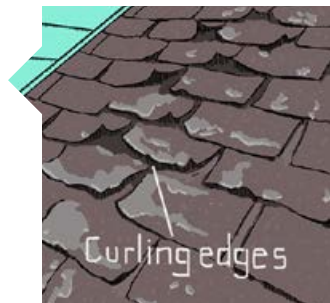

There should be no more than three layers of shingles on your roof.

More than three layers can cause heat to build up between layers of shingles and may further compromise the life of your shingles and/or invalidate the warranty.

Older homes can support more weight than most new construction, but there are limits.

NOTE: *If you do strip off all of the previous layers, check the weather. Rain isn't fun without a roof!*

TIP: *If you have leaks in your roof but don't have a budget to replace the entire roof, repair areas of active water leakage until funding for the larger project can be put in place. Or, if the roof is made up of many smaller sections, consider replacing the most compromised sections first.*

GUTTERS

Gutters are specifically designed to channel water away from the foundation of your home. If you don't maintain them, not only is there a much better chance of water finding its way into the foundation of your home, but your roof can also develop leaks.

Clogged and Leaky Gutters Can Lead to:

- > Rust and mold within the gutters.
- > Gutters pulling away from the roof due to rusted hangers.
- > A leaky roof.
- > A leaky basement.
- > Masonry deterioration and foundation issues because water is not being channeled away from the house.
- > Insect infestation inside the gutters.
- > Sidewalk or driveway damage.
- > A drowning landscape.

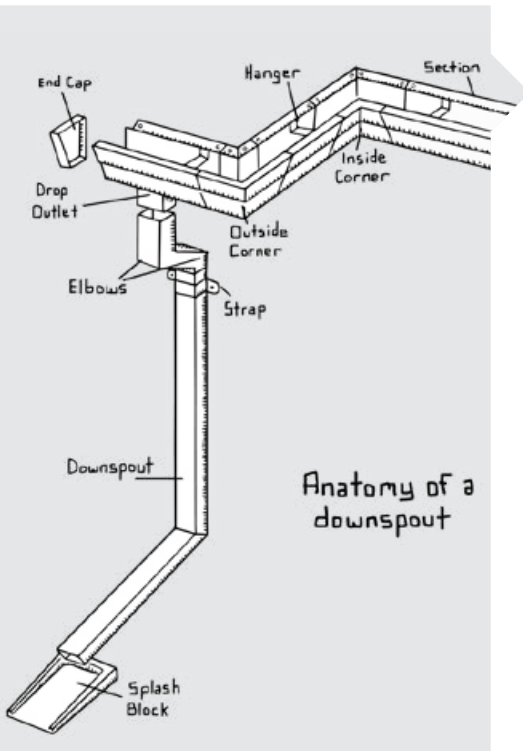

How to Keep Gutters Clean:

- > Stand on ladder and clean out as much gunk as you can. (Be sure your ladder isn't pressing against your gutter and denting it!)
- > Make sure the hangers are secured and in good condition.
- > Look for holes/cracks at the gutter seams.
- > Look for excessive rusting. Replace portions if needed, but don't mix metals or deterioration will actually worsen.
- > Make sure gutters are pitched towards the downspouts.
- > Flush the remaining gunk down gutters. If using a pressure washer, don't let the blast of water hit the shingles because this will damage them.
- > Make sure the downspout drains several feet away from the house. Be careful up there!

FLASHING

Flashing is a thin layer of waterproof material that keeps water from getting into places it doesn't belong.

Where Should it be Installed?

- > Above all wood trim on shelves, doors, and windows.
- > Where exterior stairs and decks attach to the house.
- > Where dormers intersect with the roof.
- > Wherever there are roof transitions.
- > Around any features in the roof structure, such as vents and chimneys.

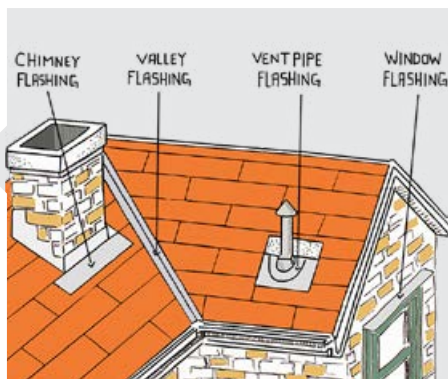

What Materials Should You Use?

Flashing can be made of sheet metal (copper or stainless steel), plastic, or composite materials. Sheet metal flashing is the most durable, and usually the most expensive choice. Plastic flashing, usually PVC-based, is a less expensive alternative to metal, but will degrade if exposed to the sun's ultraviolet (UV) rays.

What About Caulk and Other Sealants?

Caulk is fine for filling small gaps around windows and doors, but shouldn't be confused with flashing. Also, do not caulk horizontally along siding or at the base of storm windows. That just traps water in instead of letting it flow out.

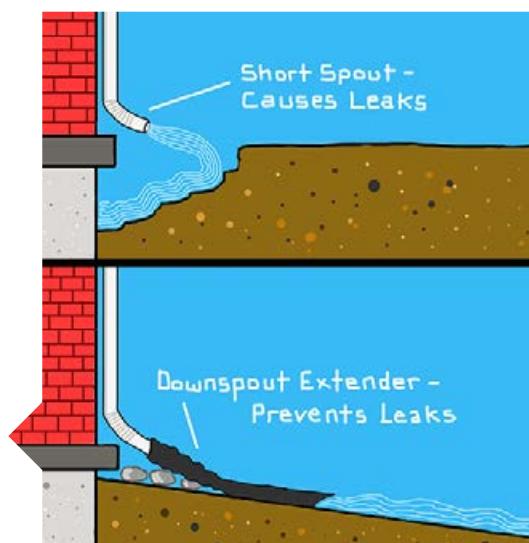

TIP: When determining a maintenance plan, consider cleaning your gutters and downspouts while inspecting your roof (generally once a year). That's one less treacherous trip upwards!



Never use caulks and tars along roof seams or chimneys. The material will become brittle and inflexible and fail in about a year's time. If there is already metal flashing underneath the tar, a chemical interaction can occur that will further erode the existing metal flashing.

You should only need a bead! If the gap you are sealing is too wide (exceeds 1/4" x 1/2"), it isn't a matter of adding more caulk. Before you caulk, you'll need a backer rod, which is an extruded foam rod typically placed in deep joints to fill in the space before the caulk is applied.

Roof with an Ice Dam

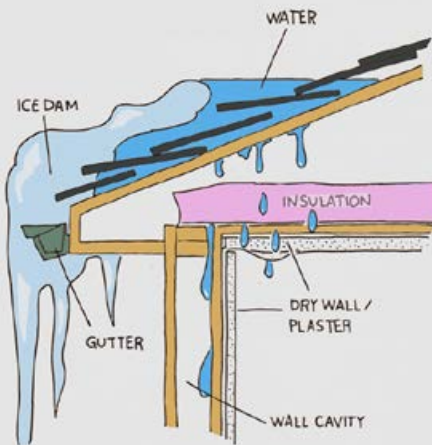

ICE DAMS

This is common with bungalows and can cause a lot of damage if not addressed. Here's how it happens:

If there is a buildup of heat in your attic and improper ventilation, snow on your roof can melt and slide down to the end of your eaves.

Bungalows have eaves that extend beyond the boundary of the attic space, so the ends of your eaves, which are not receiving heat from the attic, are as cold as the air outside.

Once the melted snow reaches the ends of these eaves, the water freezes due to the temperature change.

Cap and Flashing Details

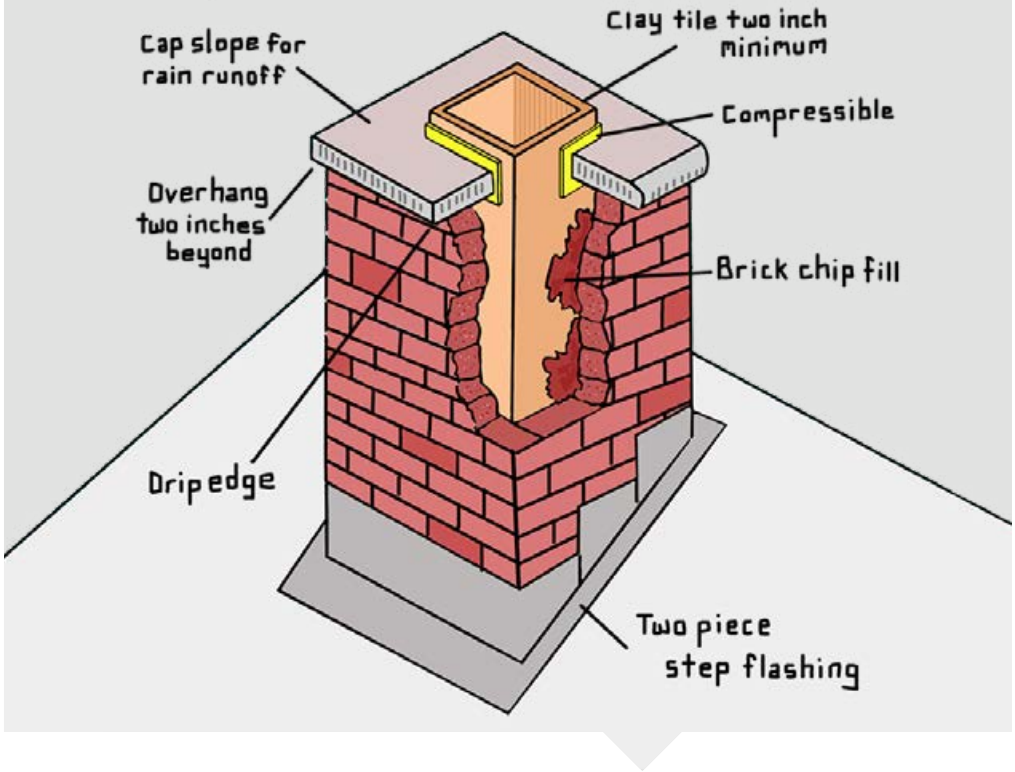

Ice formed at the end of the eave can expand and damage your shingles in this area, create issues with your gutters, and allow water to enter your attic and walls.

To prevent this, properly air seal and insulate your attic, then be sure to have proper ventilation with soffit and ridge vents to circulate air.

Is Your Chimney Leaning?

While you're 30 feet in the air, you may as well take a good look at the condition of your chimney. Even if you are no longer using your fireplace, the masonry must be inspected to make sure that tower of brick doesn't tumble over and smash your neighbor's roof or someone in your gangway. For more information on proper brick repointing, see the section on Masonry.

THE WALLS

Chicago bungalows were built of high quality brick, limestone, and old growth wood that, unlike new building materials, ***can easily last another hundred-plus years if properly cared for.***

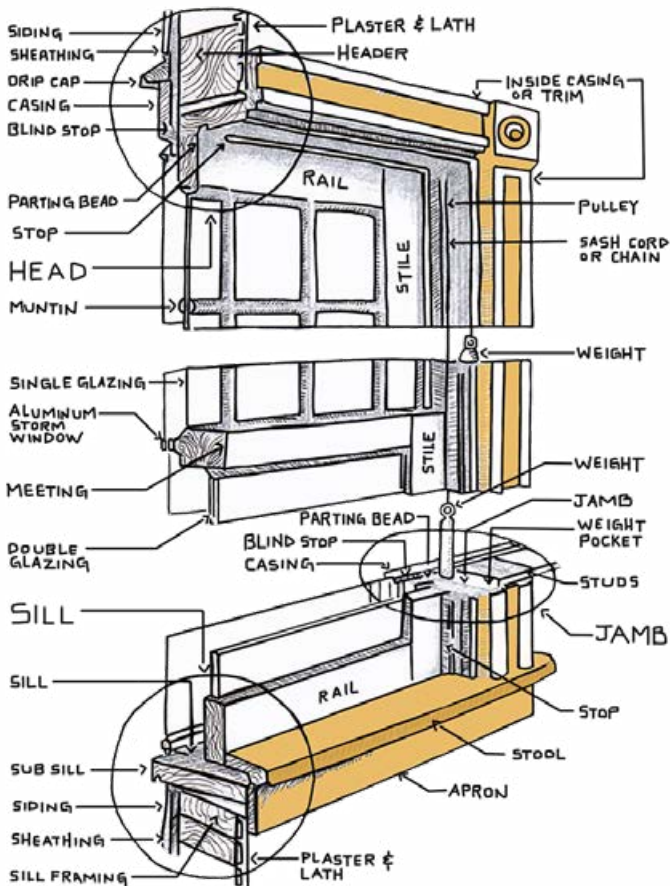

MASONRY (BRICK AND LIMESTONE)

Common Problems Affecting Your Masonry

Efflorescence. A white powdery substance found on the face of your brick. This white substance is made of salts and minerals that have migrated to the surface, usually due to repointing (aka tuckpointing) a wall with a mortar that is too hard for soft, historic brick. Water must be allowed to evaporate through the mortar, which is the sacrificial element of a wall. If the mortar is too hard, water is forced into the brick and as it evaporates, salts and minerals from the clay are brought to the surface of the brick.

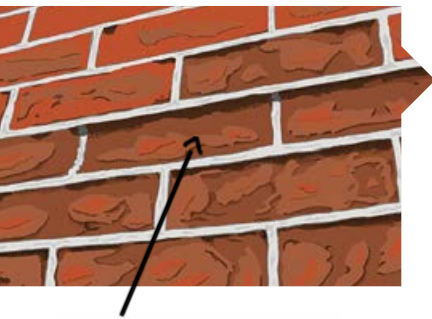

Brick face missing due to subflorescence

Spalling. If your walls are exhibiting efflorescence, keep a close eye on it because the salts can wreak havoc if they crystallize beneath the surface—a process called subflorescence. The salt crystals trapped just beneath the surface of the brick can shrink and swell with wetting and drying cycles, forming crystals large enough to cause the face of the brick or stone to spall. With spalling, the front enamel of your brick will flake or fall off, exposing a softer center that will quickly continue to deteriorate. If a water-repellent coating has been applied, this can make the problem worse because it reduces the flow of moisture out from the subsurface of the masonry.

Both of these conditions are often caused by the improper repointing of your brick. Older brick is softer than modern brick, and the mortar used to repoint your walls should also be softer, meaning it should have a higher lime content. If a hard mortar made with Portland cement is used, water cannot evaporate through the mortar and will instead be forced into the masonry unit: your brick. Unfortunately, most masons default to a Portland mortar because it is commonly used on new construction. Be sure and ask your mason or mortar supplier for a lime-based mortar or “Type O” mortar and save your brick and limestone from numerous deterioration issues.

Sealing Your Masonry Walls

Sealing your historic masonry is not recommended. Although many newer water-repellent products are more breathable than their predecessors, they can still be damaging if applied to masonry that contains salts because they limit the flow of moisture through masonry and expedite deterioration.

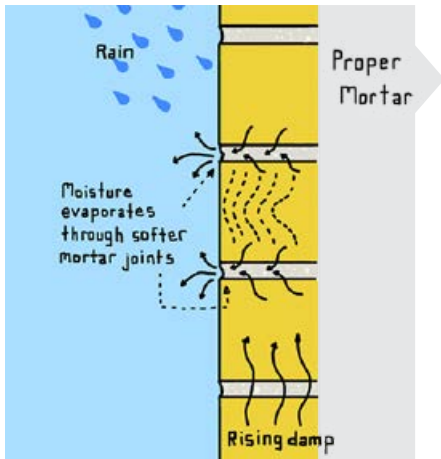
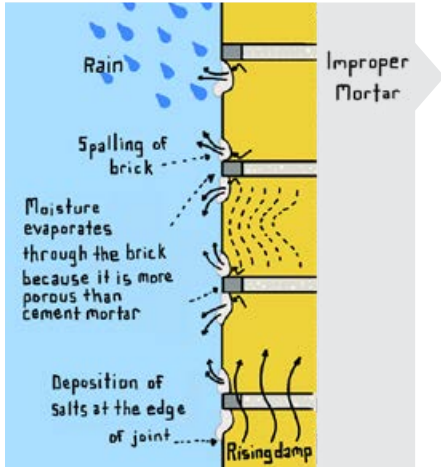

Repointing Your Wall

Your original mortar has lasted a century (go, historic mortar!), but because it was made to be the sacrificial element of your masonry wall, it may be time to repoint your walls. If there are gaps in your mortar (especially common on the brick wing walls flanking your front stairs), repoint your wall using a lime-based or “Type O” mortar and by properly cutting in the joints of your walls.

Remove mortar carefully and keep in mind that you need to chip out your joints to a minimum dept of two times the width of the joint. So, if the joint is 1/2" tall, remove to a depth of 1".



Only use a power saw on your horizontal joints. Vertical joints are too short and the blade will cut into the brick, which will ultimately compromise the unit. Use a chisel to chip out the vertical joints.

Collect your dust while you remove the mortar. The city requires it and it really does make a huge mess.

Use an appropriate, lime-based mortar. If one is not easily found, a “Type O” mortar can be used.

Match the color of your mortar. Take into account that the existing mortar has changed color with age and pollution.

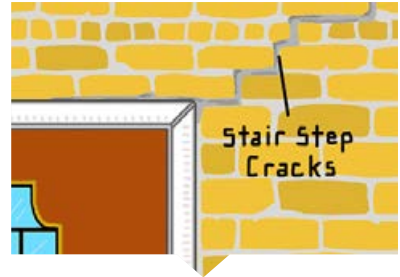

Cracks at the Corners of Door and Window Opening

Cause: Your steel lintel has rusted after decades of taking on moisture. When steel rusts, it expands, causing cracks to form.

Remedy: Replace your lintel

A typical indicator that it's time to replace your lintel is a zigzag pattern at the corners of your windows.



- Carefully remove brick above window.
- Remove old lintel (look at all that rust!).
- Prime new steel lintel with rust inhibitor and paint.
- Install continuous flashing with drip edge and end dams.
- Replace brick.



Cleaning Your Brick and Limestone

Inappropriate cleaning and coating treatments are a major cause of damage to historic masonry buildings. While either or both treatments may be appropriate in some cases, they can be very destructive to historic masonry if not selected carefully.

Masonry cleaning methods are generally divided into three major groups: water, chemical, and abrasive.

- Water methods soften the dirt or soiling material and rinse the deposits from the masonry surface.
- Chemical cleaners react with dirt, soiling material, or paint to effect their removal, after which the cleaning solution is rinsed off the masonry surface with water.



- Abrasive methods include blasting with grit, and the use of grinders and sanding discs, all of which mechanically remove the dirt, soiling material or paint—and, usually, some of the masonry surface—causing great damage a few years down the road.

It is always best to go with the gentlest cleaning process available. Once the enamel of your brick or surface of your limestone is compromised, the masonry unit cannot be saved!

Protecting Your Masonry

- Clean gutters and make sure downspout runs several feet away from your foundation wall. (See Roof and Gutters chapter for more information.)
- Make sure sidewalks, gangways, and the soil around your home pitch away from your foundation. Keep in mind that over time, soil will erode and need to be built back up.
- Remove ivy and vines, as they will hook into your mortar and pump water into your wall. Yes, it's pretty, but it'll break your heart.
- Never, ever sandblast your brick or limestone!
- Clean your masonry with a gentle power washer set to 200 to 600 psi.
- Do not seal your historic brick.
- Use proper mortar (higher lime content).
- Do not paint your masonry. The limestone was never pure white. Just embrace it!

WINDOWS

Common Problems

- Painted sashes
- Pulleys are painted and/or rusted
- Rotted sills or rails
- Loose window putty / broken glass
- Missing hardware
- Air infiltration

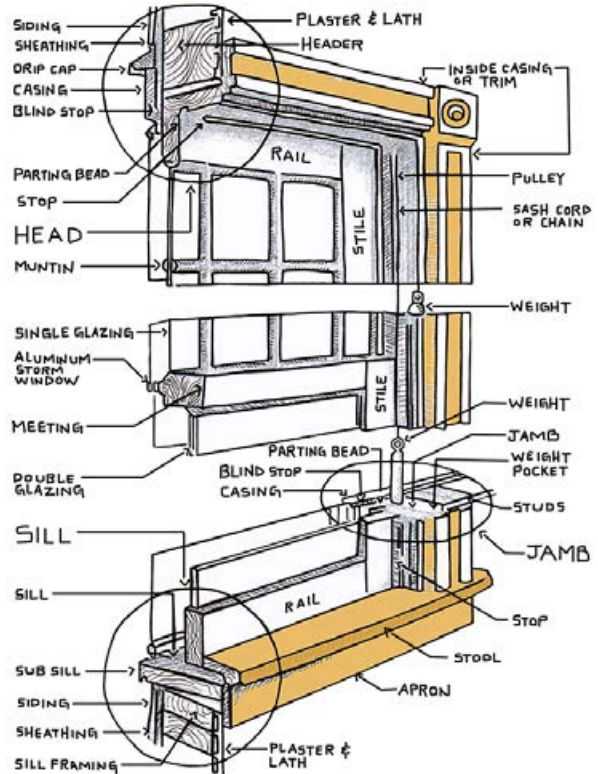

Solutions

- Use putty knives, pizza cutters, and pry bars along stops and rails to free up windows.
- Use LiquidWood to fill in holes and rotted sills.
- Remove old window glazing putty with a steam box, a heat gun, or, if the putty is dried out, carefully chip it out with a chisel. Once the putty is removed, replace with new glazing putty. Always use lead-safe practices. Heating old paint can vaporize the lead, causing a hazard.
- Look for missing hardware online and at resale and antique shops.
- To reduce air infiltration, be sure your windows are adjusted properly in their frame, install weather stripping, and use the sash locks.

TIP: Clean your painted hardware easily by soaking in a crock pot!

Reglazing

Tools needed:

- > 1-1/2" putty knife (for tooling putty)
- > 5-in-1 painter's tool (to scrape out old putty)
- > Heat gun (for softening old putty)
- > 1" paint brush (for priming sash)
- > Crawford's Natural Blend Painter's Putty, or Sarco Glazing Putty (glazing compound)
- > Glazier's points
- > Exterior primer

Steps:

- > Soften glazing and remove.
- > Examine wood for damage.
- > Make any necessary repairs with wood epoxy.
- > If replacing glass, measure wood to wood opening and subtract 1/8".
- > Lay down a thin layer of glazing compound, insert glass, and push in Glazier's points.
- > Roll putty in hands and make a snake (or a breadstick if you fear snakes).
- > Press putty into the glass.
- > Run the knife at an angle to smooth it off.
- > Wait a week or more for curing process—follow the manufacturer's recommendation.
- > Use a high-quality oil based primer.
- > Lap primer over the putty and onto the glass at least 1/16" to create a seal.



Exterior Painting

This should be done every 5-8 years.

- Prevents moisture penetration
- Paint on a dry, cloudy day with mild temperatures

To remove old paint:

- Scrape surface
- Lightly sand
- Clean with mineral spirits

Treat raw wood:

- 2 parts boiled linseed oil
- 1 part turpentine
- Prime with alkyd primer
- Use an oil-based, or alkyd finish paint

Remember: don't paint your brick or limestone!

HEALTHY PIPES! HEATING AND PLUMBING

When Chicago bungalows were built, most heating systems were comprised of a boiler, radiators, and piping. *These heritage heating systems are remarkably quiet and efficient when properly maintained, and provide clean, dust-free heat!*

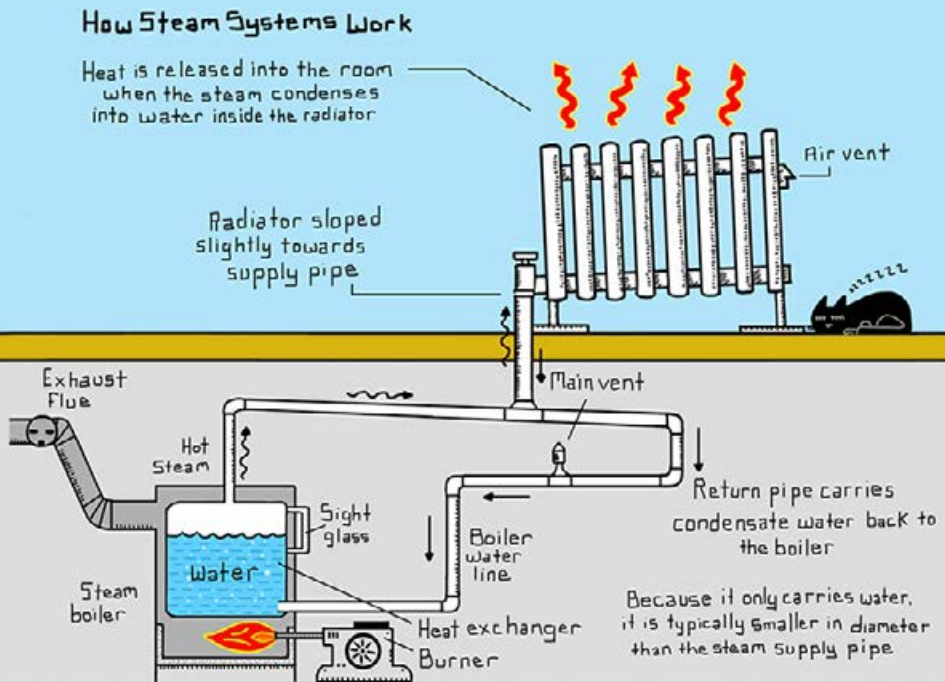

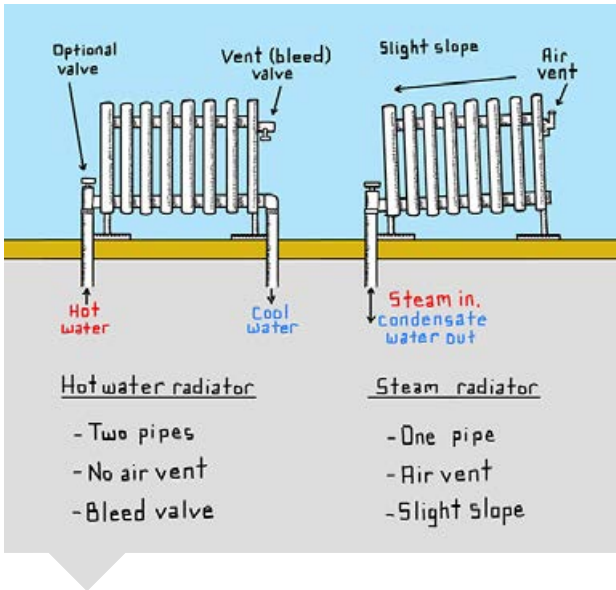

TIP: Air filters can be changed at the same time your boiler or furnace is inspected. They should be done more often than this, but grouping tasks together will cut down on steps.

STEAM AND HOT WATER HEAT

Ideally, have a professional inspect your system each fall.

- > Make sure the pilot light is working.
- > Make sure the condensate drain is not clogged.
- > Inspect piping for corrosion, leaks, pitch.
- > Do not adjust your cut-off valves often.
- > Banging noises are usually caused by incorrectly pitched pipes.
- > Cheap valves are often the culprits of hissing noises.
- > Check for evidence of a water or gas leak.
- > The pitch of your pipes will make a huge difference in how well the steam is able to reach your radiators, and these pipes are often moved around over time.
- > Hot water heaters need bleeding, which is the process of opening an air vent to allow the trapped air to escape so the flow of water can continue. Steam radiators do not require bleeding.
- > Consider a high-efficiency boiler if it's in the budget.

TIP: Heated air should flow freely around each radiator. Decorative covers should have plenty of openings, and never install heavy curtains in front of the radiator. Try to leave a space of several inches between the radiator and any furniture.

COMMON PLUMBING ISSUES

Leaking Pipes

- › Regularly check for leaks in places like below your bathroom and kitchen sinks. Small leaks can lead to much larger issues such as water damage, rot, and mold.

Causes of Low Water Pressure

- › Corroded galvanized pipes expand and block or slow the flow of water.
- › Debris, sediment, hair, and calcification can build up and narrow the diameter of the pipes.
- › A broken or partially blocked main sewer line in the yard. Older drain pipes may have separated over time or have tree roots growing into them. To determine your problem, hire a licensed plumber to snake the line to find the issue underground.

Slow Drains

- › Drain pipes need gravity to properly bring water towards the sewer source. Drain pipes should have a 1/4" -per-foot pitch, although 1/3"-per-foot is allowed if the drain pipe is 3" in diameter or larger. An improperly pitched pipe can allow for leaks and/or a slow draining of a sink or bathtub.
- › Drain pipes should have a smooth interior wall. Corrugated drain pipes are sold at many hardware stores and used under kitchen or bathroom sinks, but a licensed plumber would never use these. Plumbing standards forbid corrugated pipes due to their tendency to clog and because they are difficult to clean.

Drain Stop No Longer Functioning

- › Older drain stoppers use a chain system to stop the flow of water from the drain when the lever is engaged. Sometimes, one or more parts of this chain system can come apart and the lever gets stuck. A licensed plumber may be required to make needed repairs.

Frozen Pipes

- > Your pipes will only freeze if they are in unconditioned spaces, outside of your thermal envelope. This isn't common in bungalows unless piping has been added to your enclosed back porch, adjacent to your exterior walls.

Sewer Gas

- > All plumbing fixtures (other than toilets) require a trap in their drain pipe. A P-trap helps prevent sewer gases (and vermin) from entering the home through the drain pipes. If there is a leak in the trap or if you haven't used the faucet for a long time, these traps can dry out—this is the most common cause of a sewer gas smell. You can fill a dry P-trap by flushing (if the trap is part of a toilet), pouring water in a floor drain, or running water down the sink.
- > Other causes of sewer smells can be holes in the pipes caused by corrosion or cracks, a clogged drain, loose-fitting pipe connections, a stopped-up or too-short vent pipe, or a worn-out wax toilet ring.

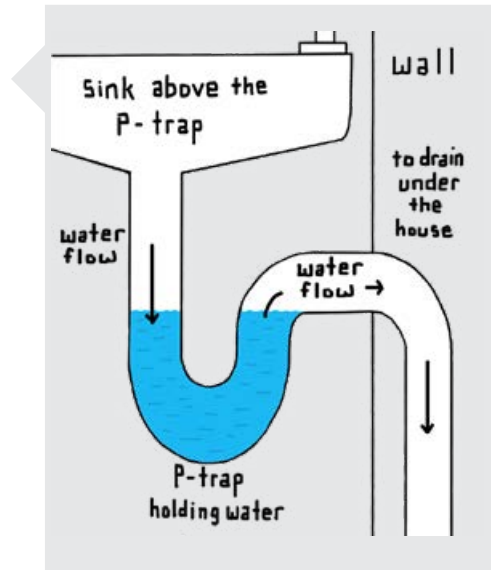

General Maintenance Recommendations

1. Insulate hot water supply pipes.
2. Turn off and drain exterior hose bibbs each fall.
3. Repair faucets when they begin to drip.
4. Maintain caulking around tubs and sinks.

ENERGY SAVING MEASURES

There are countless ways to make your home more efficient, but one thing has been proven in studies time and time again: our habits make the greatest difference. Stay on top of your maintenance plan, turn off your lights, be mindful of your water consumption and be strategic while insulating. ***It will save both resources and money!***

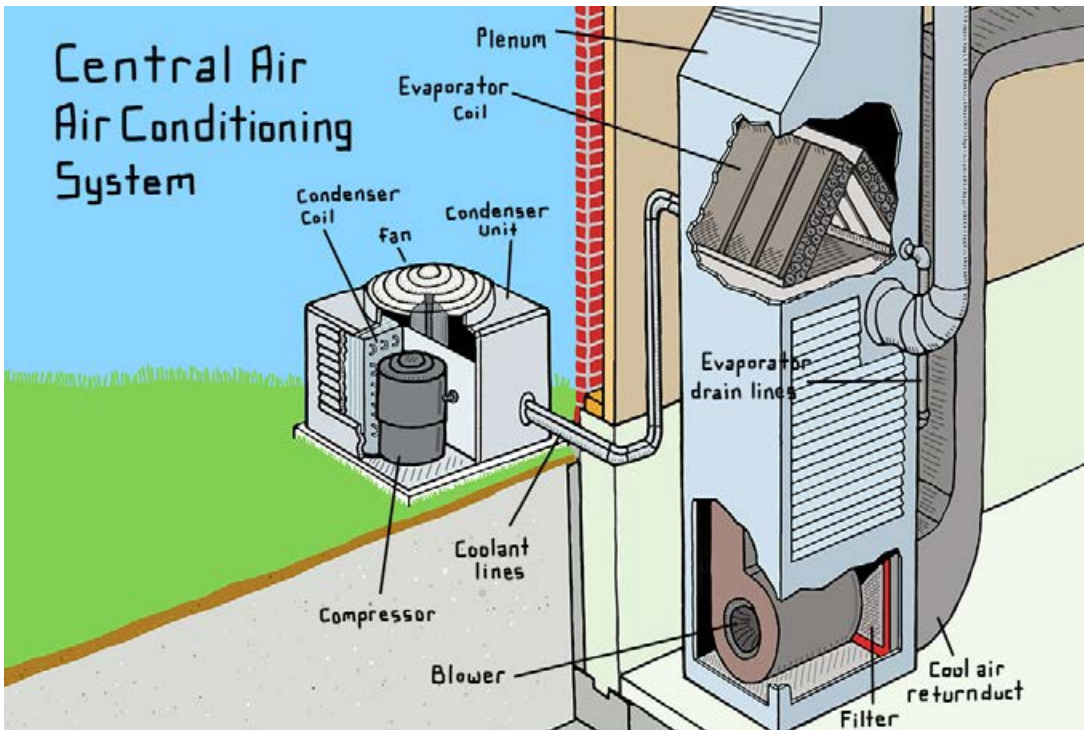

MECHANICAL SYSTEMS

- Mechanical systems have become significantly more efficient in recent years, so if you have older systems in your home, you may want to upgrade them to save more energy and money. There are often rebates and grants available through utility companies, so be sure to do your homework first, and look for the ENERGY STAR label when purchasing new appliances.
- Check all electrical connections to prevent excessive heat and failure when you're using your systems most.
- Check all gas heating components, gas valves, flame igniters, heat exchangers, safety limits, and temperature rise through the system to ensure safe operation during the heating season.
- For central air conditioning, always shut off the power first. Outside, take off the condenser/compressor's fan cage and remove any debris, clean the fins using a hose (never a pressure washer, which will damage the fins), straighten the fins, clean the area around the unit, and level the unit. Inside, clean the evaporator coil, clean a plugged evaporator drain, change the blower filter, and then turn the power back on.
- If you use window air conditioning units, be sure to remove them in the fall or the cold air will pour into your home during the colder months! Also, clean your air filters monthly in the summer, and clean your condenser coils at the beginning of each summer by removing the air conditioner cabinet and blowing compressed air, or by using a soft bristle brush and a spray bottle of household cleaner to wipe off the dirt.



AIR SEALING AND INSULATION

› Vintage homes, while built with high quality, sustainable materials, are a bit, well, leaky. The good news is that the Chicago Bungalow Association has over a decade of experience working with contractors to help reduce air infiltration. These contractors have literally gotten this solution down to a science. Often, the hardest part is finding the right installers to work in a smart, efficient, and effective way!

Thermal Boundary of the Home

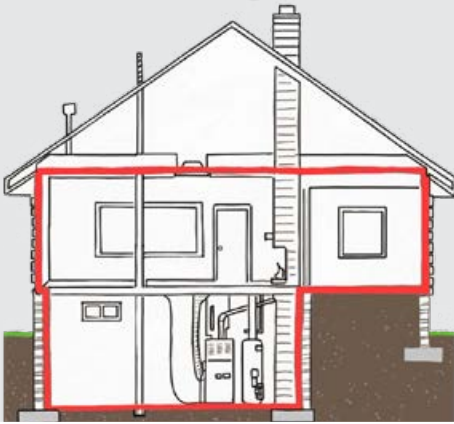

- › Determine your thermal boundary.
- › The thermal boundary of your home is a continuous boundary that separates living space from unconditioned areas. This boundary is determined by which spaces you wish to heat and cool in your home.
- › First and foremost, air seal and insulate your attic, but how and what you insulate is determined by whether you plan to live in the space, use it for storage, or leave it empty. Your thermal boundary will be impacted by these decisions, as will the cost to insulate your attic, so think ahead!
- › NEVER insulate both the floor joists and the attic ceiling. This will trap hazardous gases in your attic space.

Common Air Leakage Paths in Houses

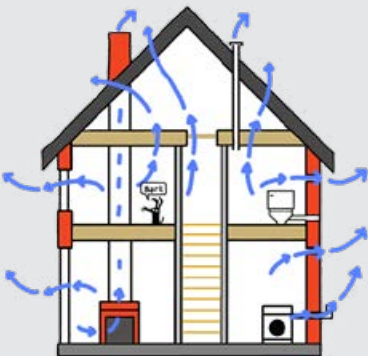

Air Sealing - Interior

- › Always air seal before you add insulation! Air sealing is the least expensive, most important part of keeping out air infiltration. If you insulate first, you won't be able to reach all of the areas that need to be air sealed with foam.
- › If possible, have a blower door test performed on your home before and after you air seal and insulate to ensure that air infiltration has been significantly reduced.

Typical places requiring air sealing in a Chicago bungalow:

Attic:

- Below your knee walls.
- Around your plumbing chase.
- Gap at the perimeter between the exterior brick and interior wall surface.
- Around any can lights (be very careful with these as insulation can cause a fire hazard if not installed properly).
- Around your masonry chimney.

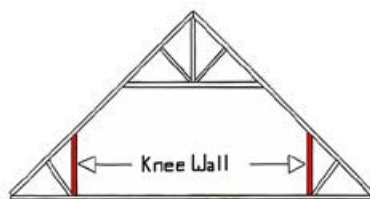

Basement:

- Around your rim joist.

Insulation

Insulate after you have air sealed your unfinished attic:

- If you are not planning to store items in your attic, blown in cellulose insulation can be added to reach the proper R-value and left as-is (least expensive option).
- If you are planning to use the space for storage, leave a narrow walkway in the center of the attic space.

After you have air sealed your finished attic:

- If you plan to use your attic space as an office or bedroom, do not insulate the attic floor, insulate the rafters instead.
- Because your roof is made of wood beams and not masonry, you can insulate a variety of ways. Foam insulation, which has the highest R-value, is also the most expensive.

TIP: *R-value is the capacity of an insulating material to resist heat flow. The higher the R-value, the greater the insulating power.*

- The overhanging eaves found on Chicago bungalows help with the amount of sunlight that enters your home at different times of year and gives them character, but will need some special attention when it comes to insulation.
 - These outer eaves should be insulated to R-49, and baffles should be installed for airflow (see section on ice dams).
 - Knee walls should be insulated with R-19 batt insulation and covered with a moisture barrier.

For a list of certified contractors familiar with the unique layout of a Chicago bungalow, visit www.chicagobungalow.org. These contractors understand strategic placement of sealing foams and insulation to best to stop infiltration.

Enclosed back porch:

- Most bungalows have a (very cold) enclosed back porch, but there is hope!
 - Attach rigid board to the underside of the floor joists.
 - Fill the cavity with cellulose.
 - Insulate the frame walls of the porch.

Where and where not to caulk

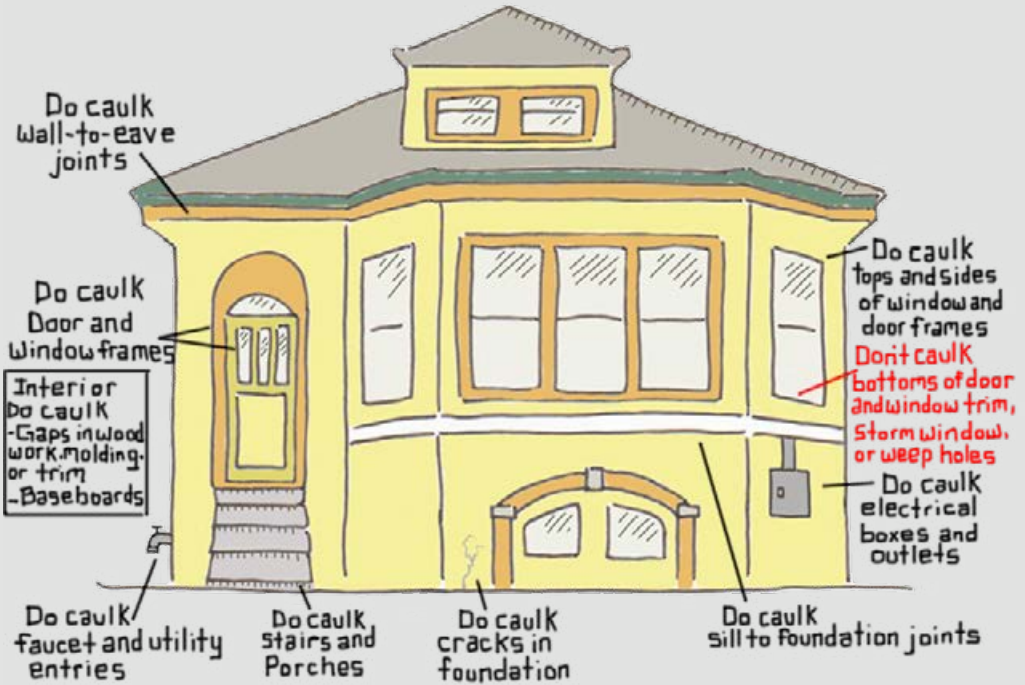

Exterior Sealing

Caulk is a sealant that fills gaps, cracks, nail holes, and similar imperfections on the surface. It is applied where moisture would otherwise penetrate and cause deterioration, and can be done with just your fingers and a caulk gun. The trick is knowing where to caulk. Caulk will eventually deteriorate due to UV damage and need to be replaced, but don't worry about removing the old caulk beforehand. Unlike your bathtub caulk, you should leave the previous coats where they are or risk damaging the materials when you pull and scrape it out.

Caulk:

- Where corners meet other planes.
- Butt joints (vertical joints), on wood siding.
- Trim boards and wood windows.
- Garage door trim (but never any part of the garage door itself).
- Imperfections in the siding, such as gaps, cracks, failed knots, etc.

Do NOT caulk:

- As an alternative to flashing!
- Window weep holes, which are designed to let water out of your windows.
- Along the bottoms of siding boards; doing so will not allow water to drain downwards.
- Metal flashing and wood-to-metal joints.
- Siding nails.
- If the gap is larger than 1/4", don't try and fill it in with caulk unless using foam cording (backer rod) as well.

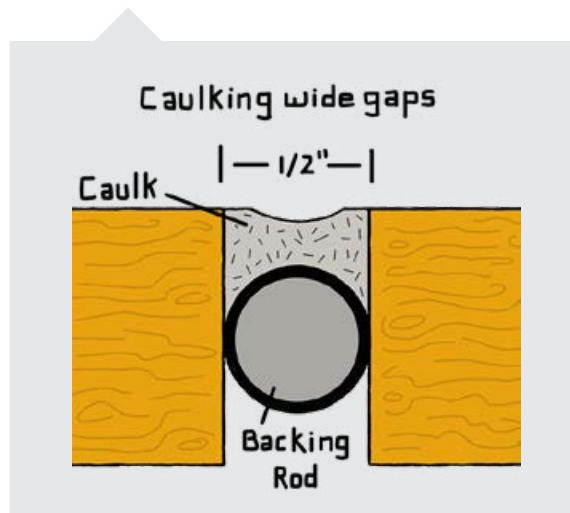

DETERMINING A MAINTENANCE PLAN

We've covered the basics and general priorities, but ***drafting a maintenance plan can only be done by YOU because no two homes (or homeowners) are the same.***

Seasonal Home Maintenance Schedule

Every home is unique but here are some things to help maintain a safe and healthy home

Spring



- Turn OFF gas furnace/fireplace pilot lights.
- Test sump pump before spring thaw.
- Clean chimney if needed.
- Clear gutters and downspouts, fix any leaks or misalignment.
- Clean windows, replace storm windows with screens, fix.
- Daylight Savings—turn on and off breakers, shutoff valves and test GFI outlets. Check smoke and carbon monoxide detectors and replace batteries.
- Test and flush out hot water tank.
- Vacuum under refrigerator and clean condenser coils.
- Clean out basement window wells and under decks.
- Rake and aerate lawn.



Summer



- Pump septic tank.
- Repair any cracks in foundation, siding or roof.
- Clean faucet aerators and shower heads.
- Check and repair caulk and grout.
- Re-glaze windows, if needed.
- Monitor basement humidity—less than 60%.
- Clean or replace any air conditioning filters.
- Check basement pipes for condensation.
- Check air conditioning system.
- Seal off any exterior holes.
- Clean and lubricate sliding door tracks.



Fall



- Clean and store patio furniture.
- Trim trees touching roof or gutters.
- Check and clean gutters and downspouts.
- Drain outside water spigots and store hoses.
- Check caulk and weather stripping around windows and doors.
- Service heating system.
- Prune and trim trees and shrubs and remove debris.
- Rake and fertilize the lawn.
- Check snow blower is working.
- Clean, sharpen and store garden tools.
- Turn gas pilot light ON.

Winter



- Pour water down seldom used drains.
- Clean out dishwasher food filters.
- Daylight Savings—turn on and off breakers, shutoff valves and test GFI outlets. Check smoke and carbon monoxide detectors and replace batteries.
- Clean kitchen and bathroom exhaust fans.
- Clean humidifiers 2-3 times during the season.
- Check fire escape routes.
- Ensure air vents are not blocked.
- Check furnace filters monthly.
- Use LED lights at the holidays.
- When replacing appliances, look for Energy Star label to save money.



This is just an example!
Your Home Maintenance
Schedule should reflect
your home's specific needs.

There are some excellent examples and guides online, which offer ideas on how to structure your personal plan of attack, how often to check or replace items, and how to budget to get the most bang for your buck.

GENERAL TIPS

- > Always prioritize health, safety, and keeping water out of, and away from, your home.
- > Group tasks together.

For example, If you're already on the roof to check out your chimney, look over your gutters and flashing.

- > Set money aside, plan out both a short- and long-term maintenance schedule.

For example, if things aren't critical, but you anticipate needing new mechanicals or a new roof in 5 years, don't wait 4 years to start saving.

- > Before planning to put an addition on your home, consider how you may be able to use space differently to achieve your needs. This will save you a huge amount of money, not only in building costs, but in heating and cooling costs as well. There are countless strategies available online regarding how to make the most of your space, so do some surfing before you pile on unnecessary debt.

- > You may want to plan for your needs as you or family members age.

If you intend to stay in your home into your later years, or anticipate caring for someone who is older, plan ahead and make adjustments before mobility is compromised. It will allow you to do things in your own time and on your own budget as well.

- > Be realistic—you are not going to get 300 things done.

Focus on priorities for the next 6 months, don't expect to get everything done in a weekend or you'll likely burn out!

- > You will need a permit for a wide variety of things, including seemingly minor tasks like installing a hot water heater. For a full list, visit: [The City of Chicago website](#).
- > The contractor you hire will make a huge difference in the success of your project. Visit the [Chicago Bungalow Association website](#) for a list of trusted contractors.
- > Always save manufacturers' instructions and manuals.

DRAFTING A PLAN OF ATTACK

Take a weekend to get to know your home and surrounding property. Grab a notepad and do a walkabout. Here's what to take notice of when inspecting your property:

Outside

- Overall site
- Site drainage (where's all that rainwater going?)
- Landscaping
- Paths and paving
- Building exterior and structure
- Roofing
- Chimney
- Exterior walls and foundation
- Front steps
- Exterior windows and doors
- Porches
- Gutters

Next to everything you need/want done, mark:

M for Must
S for Should
C for Could
L for Later

Inside

- Building interior and structure
- Basement ceiling, floor, walls, back door
- First floor ceiling, floors, walls
- Second floor/attic ceiling, floor, walls
- Mechanical and electrical systems
- HVAC
- Plumbing
- Electrical system
- Venting
- Any other systems

Make a schedule that includes each task and how often it must be done. Be as specific as you can be. Remember to combine tasks whenever possible and lay the schedule out in whatever way works best for you. Some people prefer handwritten schedules, some prefer spreadsheets...all that matters is that it makes sense to you, the homeowner!

There are numerous example guides available online for free, so take a few minutes to search until you find one that works for you and your home!

GLOSSARY

Arc-Fault Circuit Interrupters (AFCIs): A type of duplex receptacle or circuit breaker that breaks the circuit when it detects a dangerous electrical arc, in order to prevent electrical fires.

Blower Door Test (below): A test used to measure the airtightness of buildings. It can also be used to measure airflow between building zones, to test ductwork airtightness, and to help physically locate air leakage sites in the building envelope.

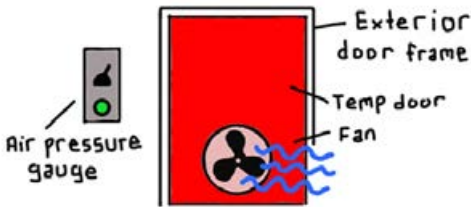

Calcification: Hard water typically has high levels of calcium and other minerals that can leave behind buildup known as calcification.

Condensate Drain: A device that automatically removes condensate from steam pipelines.

Cut-off Valves: Also called a shut-off valve or plumbing valve. Any valve used to regulate the flow of water in a potable or human waste water system.

Drip Edge: A metal flashing or other overhanging component with an outward projecting lower edge, intended to control the direction of dripping water and help protect underlying building components.

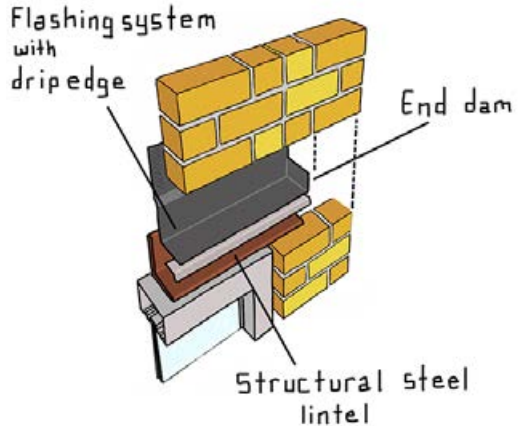

End Dams (above): Internal flashing (dam) that prevents water from moving laterally within a curtain wall or window wall system.

Floor Joists: Any of the small timbers or metal beams laid crosswise in a building to support a floor or ceiling.

Ground Fault Circuit Interrupters (GFCIs): A device that shuts off an electric power circuit when it detects that current is flowing along an unintended path, such as through water or a person. It is used to reduce the risk of electric shock, which can cause the heart to stop or cause burns. They can also prevent some fires, like when a live wire touches a metal conduit.

Hose Bibb: A tap having a nozzle bent downwards and supplied from a horizontal pipe.

Insulation Terms

Baffles: An item used to prevent insulation from restricting air movement.

Batt Insulation: Insulation, usually made of fiberglass, that is used chiefly to prevent heat loss and is manufactured in sheets or rolls.

Blown-in Cellulose: A plant fiber that is usually blown into walls and roof cavities to insulate and reduce noise.

Foam Insulation: An alternative to traditional building insulation such as fiberglass. A two-component mixture composed of isocyanate and polyol resin comes together at the tip of a gun, and forms an expanding foam that is sprayed onto roof tiles, concrete slabs, into wall cavities, or through holes drilled in into a cavity of a finished wall.

R-Value: The capacity of an insulating material to resist heat flow. The higher the R-value, the greater the insulating power.

Rigid Board: Panels of polyurethane foam that are generally used in commercial and residential construction as roof or outside wall insulation.

Knee Walls (below): A knee wall is a short wall, typically under three feet in height, used to support the rafters in timber roof construction.

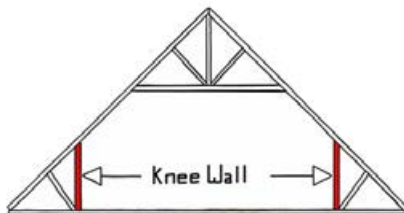

Knob and Tube Wiring (K&T): An early standardized method of electrical wiring in buildings, in common use in North America from about 1880 to the 1930s.

Lintel: A horizontal support of timber, stone, concrete, or steel across the top of a door or window.

Old Growth Wood: Refers to a tree that has naturally reached its full maturity in an environment that promotes slow growth. The slower a tree grows, the denser the fiber becomes. Old growth wood is less porous and thereby resists water, mold, and decay considerably better than new lumber.

Plumbing Chase: Also called a pipe chase. A vertical space enclosed by a chase, or false wall, for the purpose of hiding pipes. A properly installed pipe chase can run from the basement to the roof to hide plumbing.

Ridge Vent: A type of vent installed at the peak of a sloped roof which allows warm, humid air to escape a building's attic.

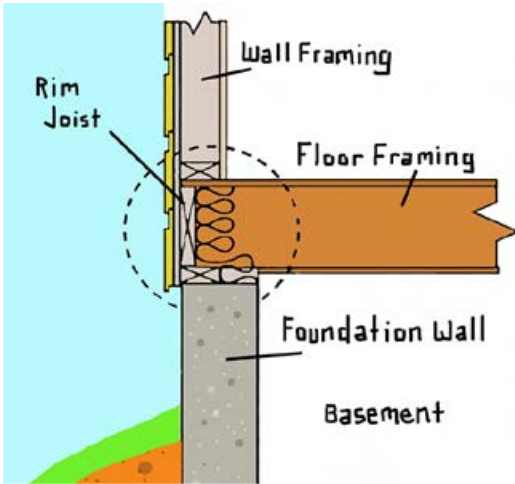

Rim Joist (above): Perimeter joist for a wood floor framing system.

Soffits (below): The underside of a part on a building, like a protective covering under the eaves of a house, or the surface of overhanging eave as seen from below.

Tamper-Resistant (TR) Receptacles: The 2008 *National Electrical Code*®(NEC®) requires new and renovated dwellings to have tamper-resistant (TR) electrical receptacles. Receptacles are the same things as electrical outlets. These receptacles have spring-loaded shutters that close off the contact openings, or slots, of the receptacles. This is required due to the number of children who have received severed shock and burns when they put items into the slots of electrical receptacles.

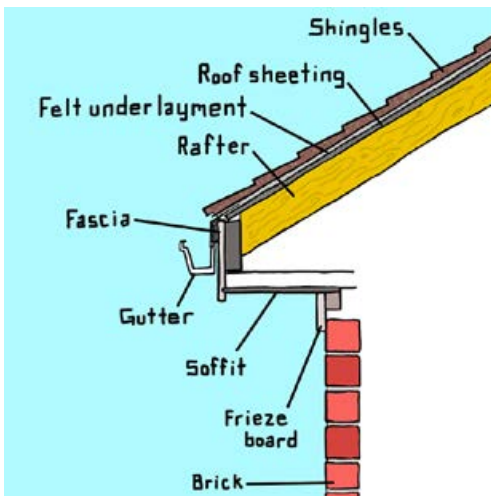

Looking for a contractor?

*Visit our referrals page at
www.chicagobungalow.org*

The Chicago Bungalow Association (CBA) was created in September 2000 to ensure that the 80,000 one and onehalf story homes that have been the foundation of family lives and neighborhoods for over 100 years would continue to do so for the next century. While the bungalows, with their sturdy brick construction and singular craftsmanship have endured the test of time, many are in need of modernization, repair and adaptation. Since it was established, the Association has offered buyers and owners unparalleled opportunities to rehab and restore their Chicago bungalows and vintage homes.

Special thanks to:

Jay Ramirez for the creative illustrations. JayDrawsThings.com

The Nimble Bee for the design. TheNimbleBee.com



CHICAGO BUNGALOW ASSOCIATION

Now serving owners of all vintage homes!

Request to join the official Chicago Bungalow Association Group on Facebook—
for discussion among bungalow owners and enthusiasts alike.



@chicagobungalow



@chibungalow



Chicago Bungalow Association

Chicago Bungalow Association 53 W Jackson Blvd, Suite 740 Chicago, IL 60604

Chicago Bungalow Association is an Illinois nonprofit corporation exempt from federal income tax under Section 501(c)(3)